

RECIRCULATORY TYPE CHARGING SYSTEM (RTCS).

Abhishek Patne^{1*}, Rushabh Pardhi², Gaurav Lucche³, Aishwarya Tekam⁴

^{1, 2}Deptt. of Mech. Yeshwantrao Chavan College of Engineering, Nagpur

³ Deptt. of Mech. Yeshwantrao Chavan College of Engineering, Nagpur.

Abstract

We have studied the very simple type of charging system by minimum power loss and maximum output. By the use of very simple mechanism, we can generate very high output of about the range of 75 volts only at the rpm of 400-500. as we have studied it is very effective idea to charge the vehicle as compared to the power loss when the alternator is connected, in this concept the power loss is going to be very low and the special effect is that the power is going to be stored in the form of rotating drum like structured permanent magnetic the form of flywheel. The another concept is to give a direct supply to the electrical supply to electronics appliances of the electrical vehicle because of which the less batteries is required to give power motor .as a result of which the efficiency of the EV will increase and also the large amount of electronics, navigation ,entertainment, and safety features will be added as in the normal fuel running car's. With this idea a great future of EV vehicle are visible in front of us.

Keywords: factors analysis; facility layout; evaluation; selection;

1. Introduction

Electric vehicle (EV) has received an intensive attention and been deployed globally due to its beneficial characteristics including higher energy efficiency and lower environmental impacts. However, immense charging of EV leads to several problems to electrical grid because of vast amount of electricity demand and its fluctuation. Therefore, charging management for EVs is urgently madden. In this case study, battery supported quick charging system is developed and its performance in single and concurrent multiple EVs charging is evaluated. The main thing during Battery installment includes maintenance of the charging rate and reducing the liability of electrical grid due to EV charging. In addition, charging behavior of EV under different seasons (winter and summer) is simplified initially. By the use of very simple mechanism, we can generate very high output of about the range of 75volts only at the Rpm of 400-500. As we have studied its very effective idea to charge the vehicle as compared to the power loss when the alternator is connected, in this concept the power loss is going to be very low and the special effect is that the power is

going to be stored in the form of rotating drum like structured permanent magnetic the form off wheel. Another Concept is to give a direct supply to the electrical supply to electronics appliances of the electrical vehicle because Of which the less batteries is required to give power motor.

2. Layout analysis

In this figure, we can see the flywheel on which the magnet are placed (fixed), on both side of the flywheel two secondary winding are fixed which will collect the charge from the flux generated by magnet, which is wired to the ECU unit which will manage the various functions of the system. ECU is going to be a brain of this system and the flywheel and secondary winding is going to work as the heart of the system. Then ECU has have three output point. Then we can see two battery purpose-fully (it'll be explained in further topics) ECU two output point is going to be connected to the batteries respectively. Remaining one point is going direct to the accessories Of the vehicle and it'll also contain the battery level indicator for the dashboard.

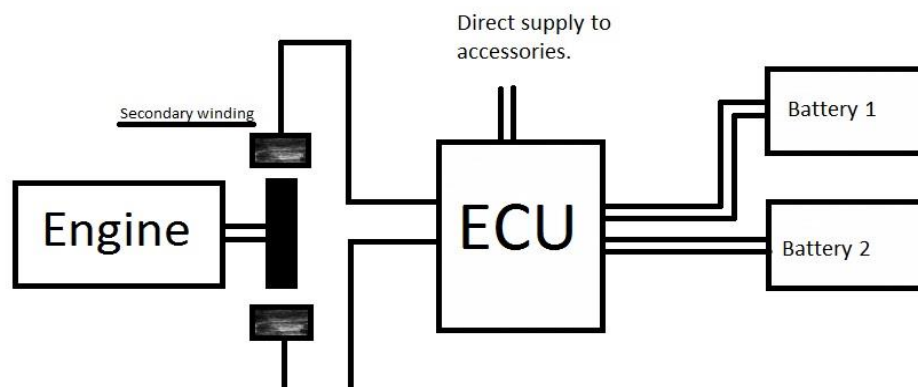

3. Results and Discussion

In this paper we have studied the very simple type of charging system by minimum power loss and maximum output .By the use of very simple mechanism, we can generate very high output of about the range of 75 volts only at the rpm of 400-500.

As we have studied it is very effective idea to charge the vehicle as compared to the power loss when the alternator is connected, in this concept the power loss is going to be very low and the special effect is that the power is going to be stored in the form of rotating drum like structured permanent magnetic the form of flywheel.

The another concept is to give a direct supply to the electrical supply to electronics appliances of the electrical vehicle because of which the less batteries is required to give power motor .as a result of which the efficiency of the EV will increase and also the large amount of electronics, navigation, entertainment, and safety features will be added as in the normal fuel running car's. With this idea a great future of EV vehicle are visible in front of us.

4.METHODOLOGY:-

The block diagram of the RTCS system justifies 90% of the system and gives the idea of circuit. Is shows the flow of the charge in the system. Each of the elements have their defined work and specified bellow in the component briefing part.

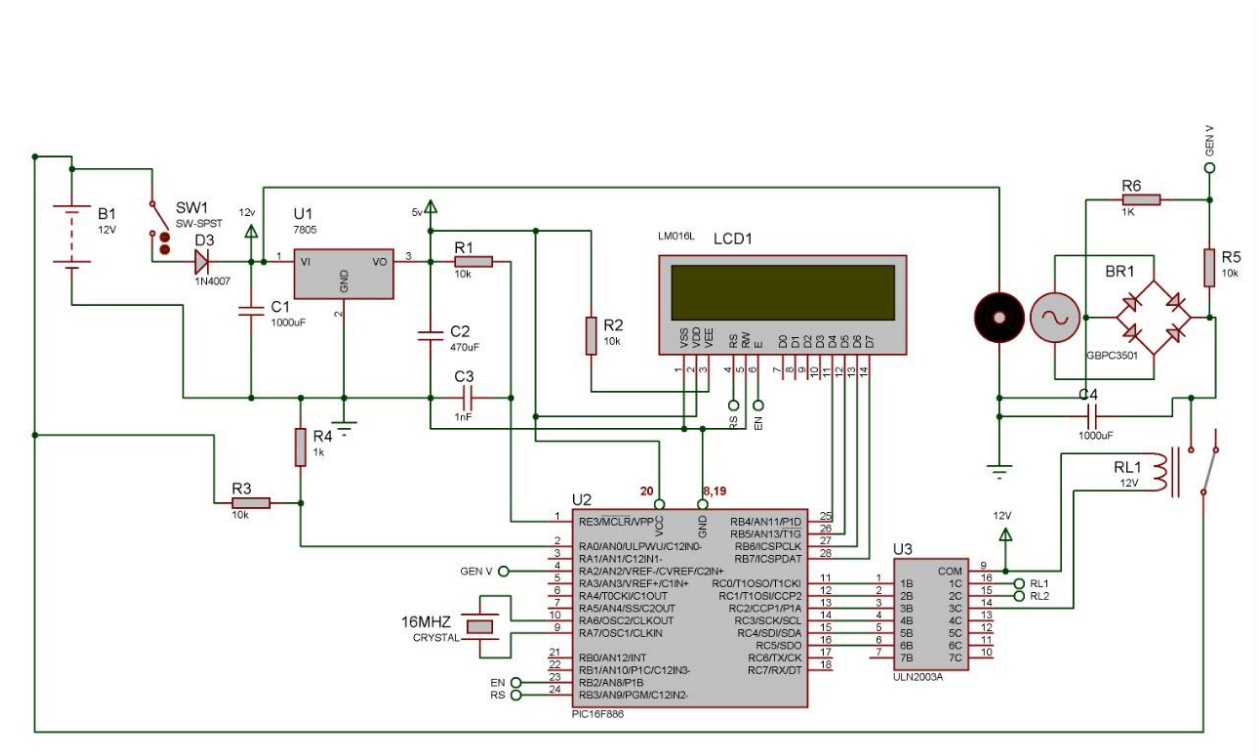

The construction of the RTCS is very simple and easy to understand. As we have seen in the fig.1.1 the system consist of very basic component and in actual application also it can be detected that what will be the alternate component can be used at higher load application. This is going to be very useful in the projects related to the EV vehicles. Declining the error or a very big problem of charging in the whole system. It is the one time investment type of project. Whatever power is going to be generated by the engine in the running vehicles or motors in the electric vehicles is going to be converted in to electric.

Means we are using generated energy of the motor to generate the input for itself, this

is the thing what we are trying to convey from the word recirculatory type or recirculating type. Here we are not wasting any kind of energy there may be some frictional losses due to the magnetic field which is the base of contact between the field winding and the magnets in the circuit.

The concept we are using,

- 1) Is generally used in generator.
- 2) Is used in the electric motors in which the magnets is replaced by the secondary winding and field is generated by the electric charge.

The system consist of,

- 1) The winding wounded on the rod.
- 2) Magnets, microcontroller, etc.

References

- [1] Bendjedia, B.; Rizoug, N.; Boukhnifer, M.; Bouchafaa, F.; Benbouzid, M. Influence of secondary source technologies and energy management strategies on Energy Storage Systemsizing for fuel cell electric vehicles. *Int. J. Hydrogen Energy* 2018, 43, 11614–11628.
- [2] Campbell, P. 26 July 2016. "Electric cars see range, battery and ease of charging as barriersto mass adoption." *Financial Times*.
- [3] Campbell, P. 26 July 2016. "Electric cars see range, battery and ease of charging as barriersto mass adoption." *Financial Times*.
- [4] K.A. Kalwar, M. Aamir, S. Mekhilef, Inductively coupled power transfer (ICPT) for electricvehicle charging – a review, *Renew. Sustain. Energy Rev.* 47 (2015) 462–475.
- [5] Kadlag Sunildatta Somnatha Mukesh Kumar Gupata, Review Paper on Electric Vehicle Charging and Battery Management System , May 17, 201
- [6] Arif , Tek Tjing Lie , Boon Chong, Soumia Ayyadi and Kristian Jensen.Review of Electric Vehicle Technologies, Charging Methods,Standards and OptimizationTechniques Syed Muhammad
- [7] Syed Muhammad Arif , Tek Tjing Lie , Boon Chong, Soumia Ayyadi and Kristian Jensen Review of Electric Vehicle Technologies, Charging Methods,Standards and OptimizationTechniques
- [8] Kadlag Sunildatta Somnatha, Mukesh Kumar Gupata Review Paper on Electric Vehicle Charging and Battery Management System , May 17,

2019.

[9] <https://www.quora.com/How-can-a-person-generate-electricity-by-his-her-own-hands-by-squeezing-shaking-or-moving-an-object-that-turns-the-movement-into-energy-and-stores-it>

Are-there-any-devices-like-that-already-on-sale

[10] <https://www.conserve-energy-future.com/advantages-and-disadvantages-of-electric-cars.php>

[11] <https://www.ft.com/content/8f79ae6e-2400-11e6-9d4d-c11776a5124d>